

# Agricultural Buildings and Conversion Barns

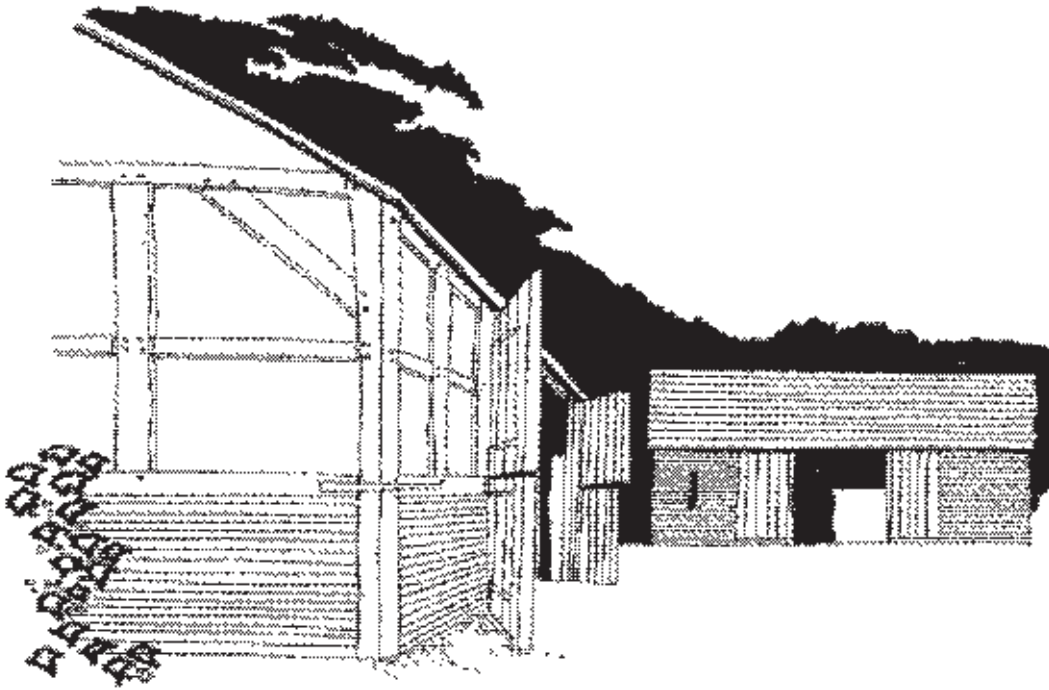

## INTRODUCTION

Barns are an important and valuable feature of the landscape. Their acceptability for conversion will depend firstly upon meeting the Local Plan policy criteria of The District Council where appropriate and secondly upon achieving proper standards of design and appearance.

The introduction of inappropriate design elements can be highly destructive to the character, historic fabric and setting of a former barn or agricultural complex.

This leaflet accordingly sets out the specific design guidance in the form of a series of do's and don'ts, with the intention of encouraging a more appropriate and sympathetic re-use of agricultural buildings.

**Specific advice on the appropriateness of the conversion of a particular barn in the light of Government guidance and Local Plan Policies should first be obtained by contacting an Area Planning Officer of Warwick District Council Planning Department.**

BARNs

## DON'T TURN THIS



## INTO THIS!

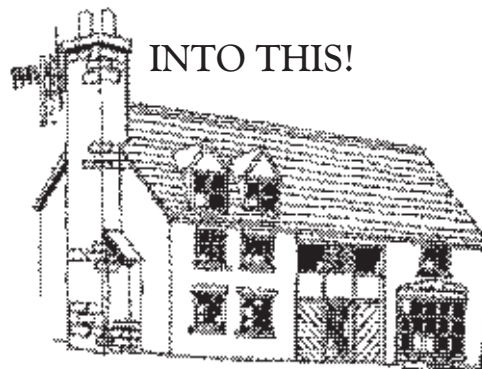

September 2002  
Conservation & Design  
Warwick District Council



INVESTOR IN PEOPLE



"Warwick District Council strives to ensure that all people, regardless of ethnic origin or disability have equal access to its services. All information will be made available in braille, cassette tape or other languages, on request"



## DESIGN GUIDELINES

Traditional buildings historically reflected the local vernacular tradition of their area.

Warwick District is no exception, with brick, timber and clay tiles roofs, being the prevalent material for agricultural buildings.

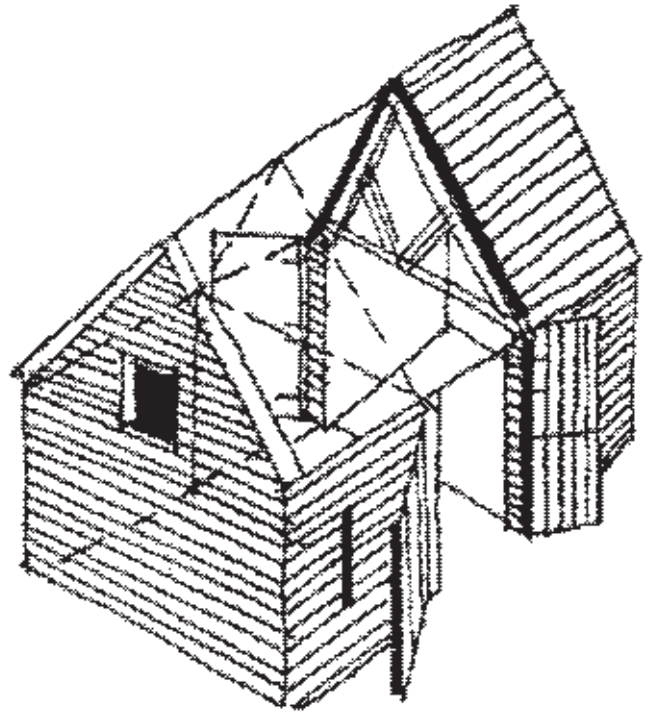
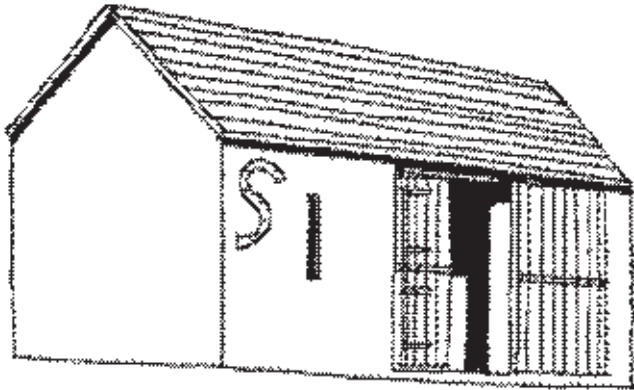

With the exception of ventilation slots and the occasional pitch or owl hole walls are characterised by their lack openings.

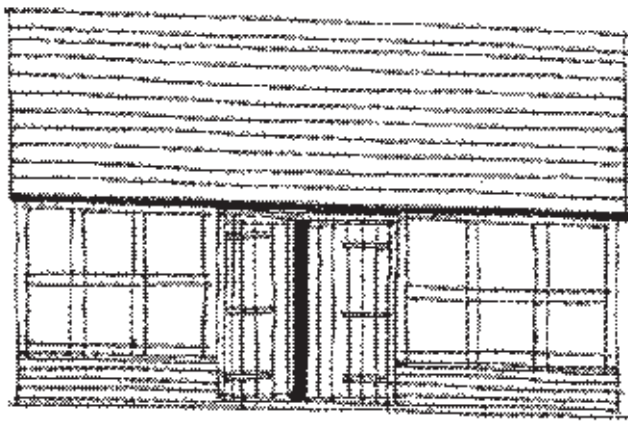

Barns were essentially used for the storage of cereal crops, their threshing (the process of loosening and separating the grains of corn from the stalks) and subsequent winnowing (blowing the lighter chaff away from the heavier grain).

This function is reflected in the character of the building - large interior voids with great barn doors to allow access for carts and to induce draught winnowing.

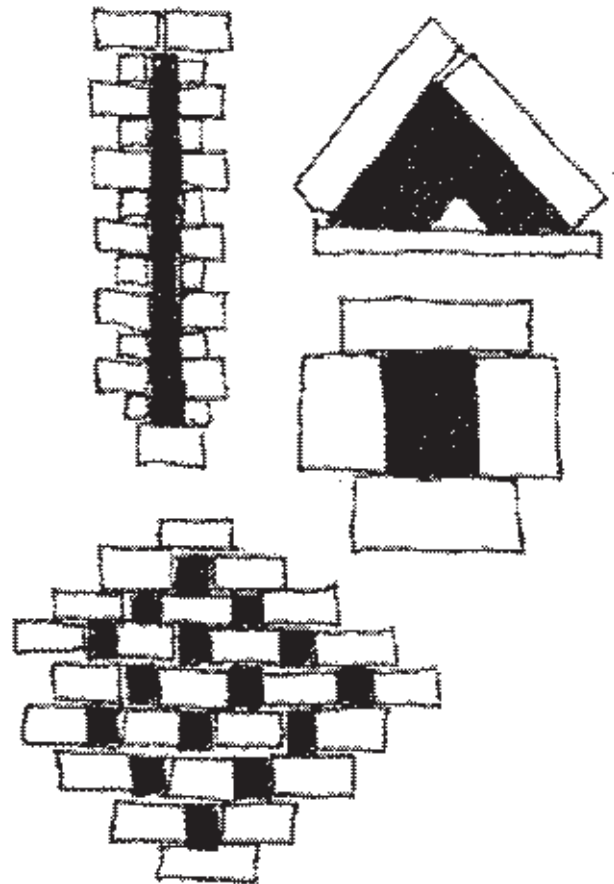

It is precisely these characteristics that are so important to respect if the integrity of a barn is to be retained and not compromised by inappropriate conversion.

## ROOFS - DO'S

With the exception of the occasional pitching loft, roofs are characterised by their unbroken lines and total lack of any openings. It is essential that this quality is retained in any conversion work.

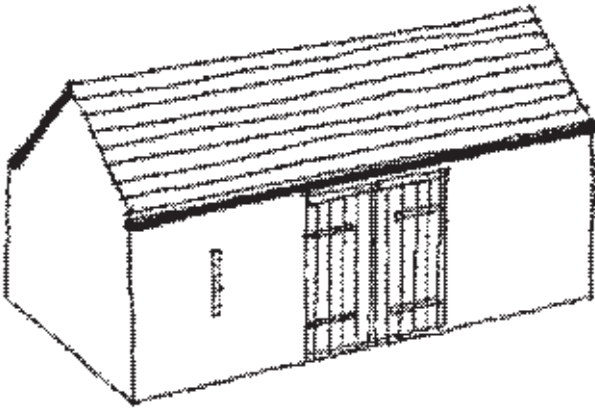

**Do** retain the roof profile and form as far as possible - breaks in the eaves or ridge line should be avoided.

**Do** retain, repair or re-instate as necessary defective/damaged or missing roofing materials using traditional replacements to match the existing.

**Do** avoid disrupting the visual appearance of the roof by roof lights - if additional daylight is required, consideration, in the first instance, should be given to using unobtrusive openings in gable ends or utilising existing openings such as pitch holes etc.

Roof lights need to be handled extremely carefully. They should be modest in size, located flush with the roof pitch and restricted to the absolute minimum and certainly located below the centre line of the roof slope, preferably in the bottom third and related to the scale of the existing building.

Consideration should also be given to varying the size and position of any new roof lights to avoid excessive symmetry and produce a more visually appropriate solution.

Nothing is so visually obtrusive as the distinctive patches of reflected light produced by a number of inappropriately sized and located roof lights.

In some situations it may be appropriate to use an area of patent glazing in lieu of roof lights.

## DON'TS

**Don't** alter the existing roof pitch.

**Don't** use inappropriate materials such as concrete tiles, asbestos slates etc. for any repair or reinstatement to the roof.

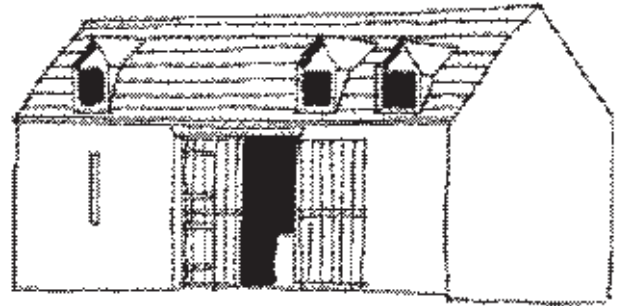

Dormer windows should not be used. These adversely affect the roof scape, introducing a totally inappropriate domestic character.

**Don't** introduce excessive numbers of roof lights - they should also be restricted to the internal side of the building complex.

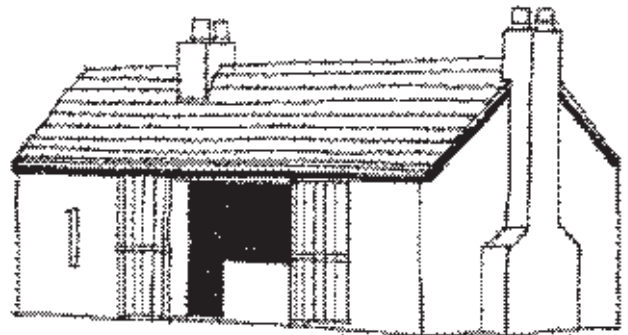

Chimney stacks are an inappropriate feature and should not be introduced. Where flues are required they should be of minimum size of metal construction and painted or stove enamelled with a dark matt finish.

They should also be sited as unobtrusively as possible.

**Don't** introduce excessive numbers of soil or vent pipes; these should, if possible, not intrude on to the main roof slopes.

Plain walls invariably form the dominant element of a barn's external fabric.

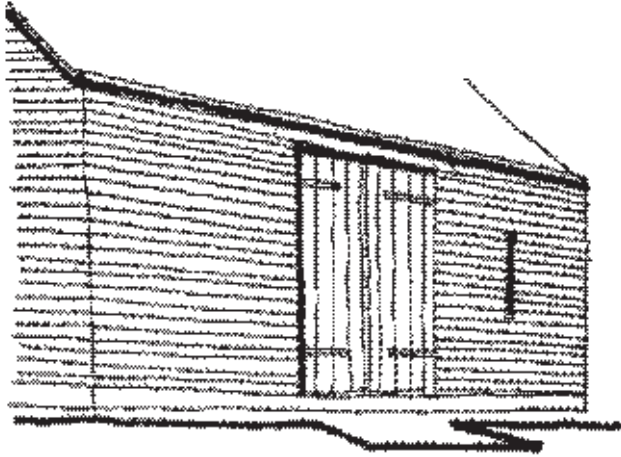

Do retain the original walling material wherever possible; making good, repairing or reinstating as necessary.

Do retain original brick plinths - making good and repairing as necessary.

Do retain original timber sole plates, unless they are in such poor condition as to warrant replacement.

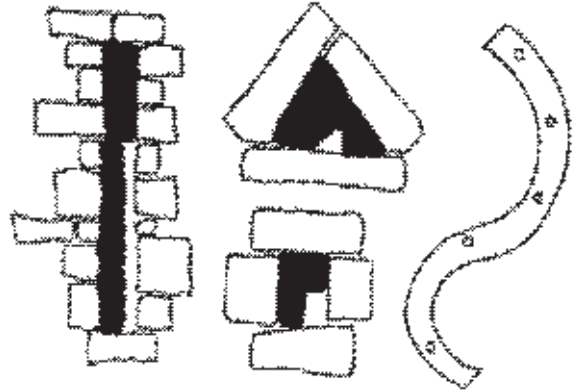

Do retain existing features such as owl or pitch holes, ventilation slits, metal straps etc. (where appropriate, such openings may be considered as sources of additional daylight and glazed by the use of light section frames set to the back of the reveal).

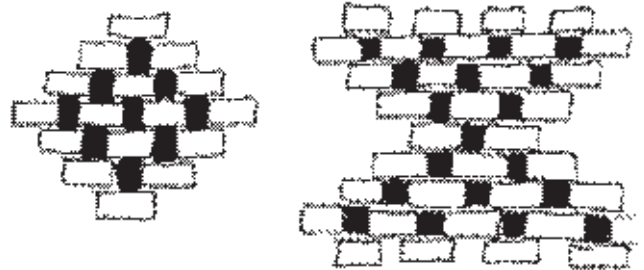
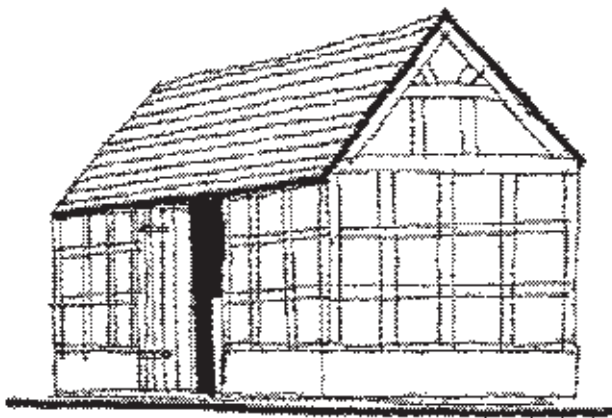

New openings have to be handled extremely carefully.

Generally they should be restricted to the internal (or private) side of the building complex.

Conversion work must be contained within the curtilage of the existing buildings: new extensions, glazed links or conservatories will not be permitted.

All repair work should be carried out using the appropriate traditional materials and techniques.

Do retain the geometric patterns of air vents often associated with brick barns.

(Half brick sections can be inserted at the rear of such vents to render them weather tight if necessary).

Do take the opportunity to remove any unnecessary and obstructive pipes, wires etc.

Do ensure that any new rainwater goods are kept to the absolute minimum, are of metal construction and are painted an appropriate dark colour (visually either black or dark brown according to the colour of the background material).

## WALLS DON'TS

**Don't** remove original walling material or features, unless absolutely necessary as an integral part of a renovation programme.

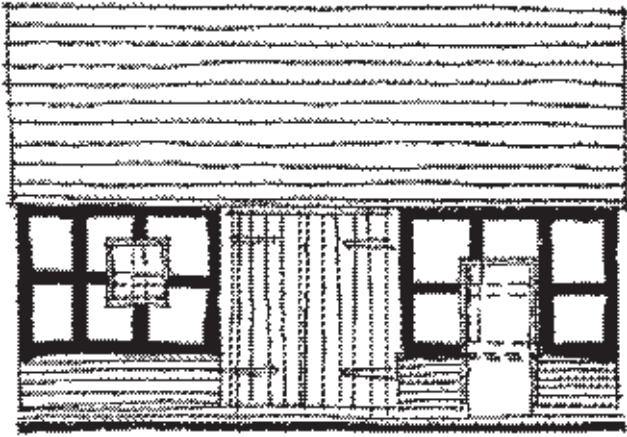

**Don't** cut through existing timber framework to form new openings.

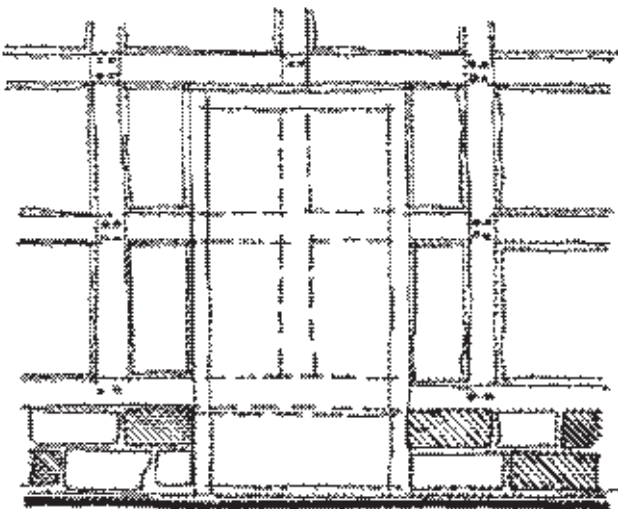

**Don't** interrupt existing brick or stone plinths with new openings or remove, unless absolutely necessary, old or original sill beams.

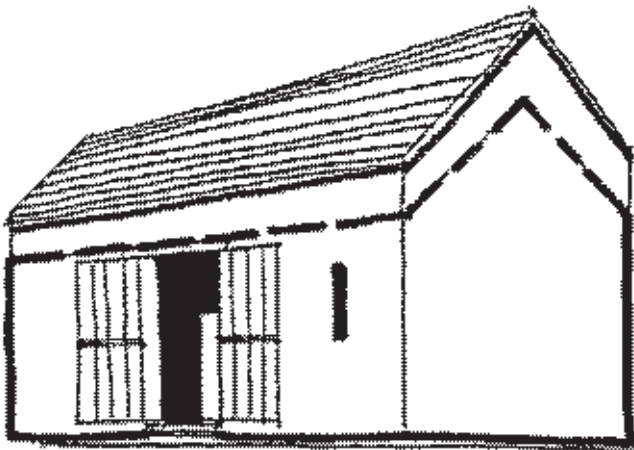

**Don't** raise the height of the existing walls

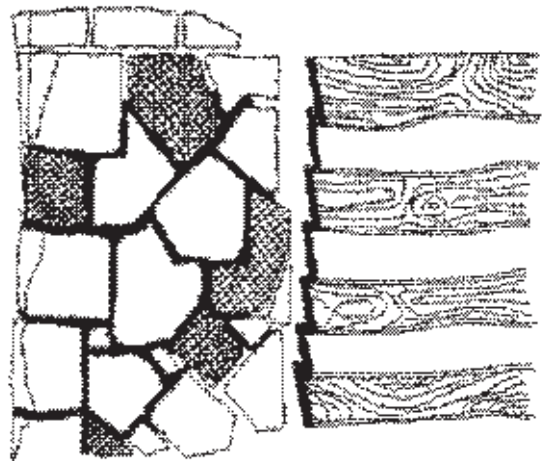
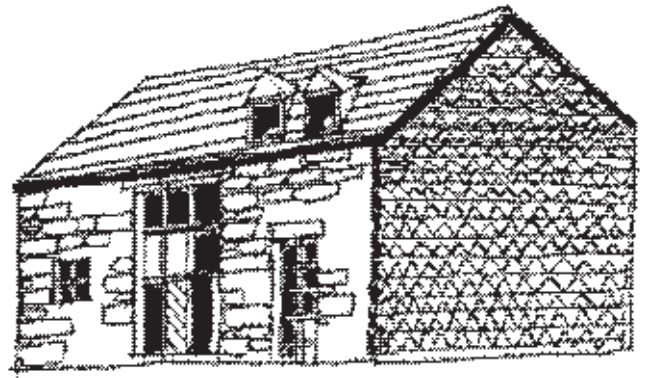

**Don't** cover unpainted brick or other surfaces with artificial cladding materials.

**Don't** paint or render natural brick or stone surfaces.

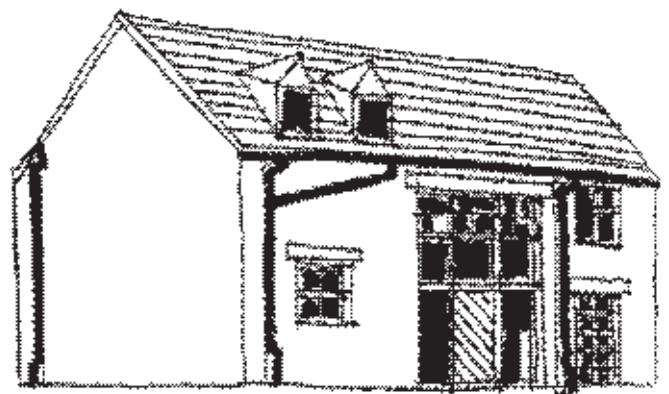

**Don't** use plastic guttering or downpipes. New rainwater goods should be kept to the absolute minimum of metal construction and painted an appropriate dark colour (visually either black or dark brown according to the colour of the background material).

## INTERIORS DO'S

Interiors of barns, by their very nature, usually comprise of a large void with roof timbers or timber framing members forming the prominent visual elements.

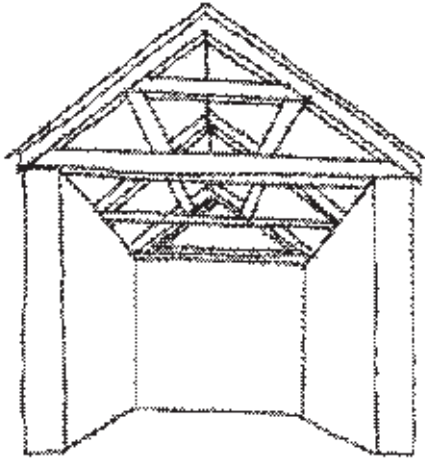

Conventional concepts of room location may well need to be revised if a sympathetic solution to interior conversion is to be obtained.

(It may be that locating bedrooms on the ground floor for example, would allow more space to be left open to full roof height at first floor level, whilst gallery bedrooms can avoid the need for additional windows or rooflights).

**Do** ensure that a substantial part of the main interior void - at least one third - remains open to its full height.

**Do** ensure that original framing members - roof truss, tie beams, bracing timbers etc. are retained in situ.

Defective/missing members should be repaired or reinstated as necessary.

**Do** respect the original floor level and materials. Existing stone flags should, wherever possible, be retained and incorporated into any new flooring scheme.

**Do** ensure that original partition walls or cross frames are retained wherever possible and not removed or damaged during the course of conversion work. (New openings for example, should be located to avoid the removal of original members).

**Do** retain any traditional features of note - carpenter's marks, mouldings etc.

**Don't** compartmentalise the interior void.

**Don't** remove original internal walls or partitions unless structurally necessary.

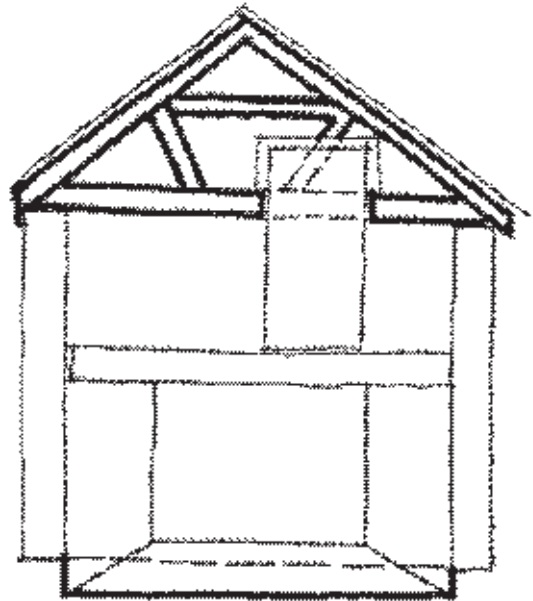
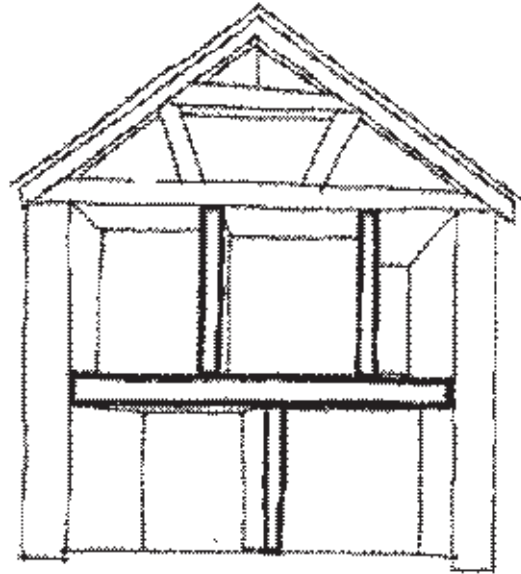

**Don't** cut existing roof trusses or remove original bracing timbers or ties. This is more important if the integrity of the original building is to be retained.

The use of half landings under roof trusses or separate staircases can obviate the need to cut trusses to gain access to the first floor.

**Don't** lower the original floor level.]

**Don't** use pseudo historic, Georgian or other inappropriate period detailing.

## WAGONDOORS DO'S

Often the focal point of the barn's exterior, wagon doors, are noted for their simplicity: vertical timber boarding with variations of two or four opening leaves.

Wagon door openings provide an excellent source of light to the interior thus minimising the need for new openings.

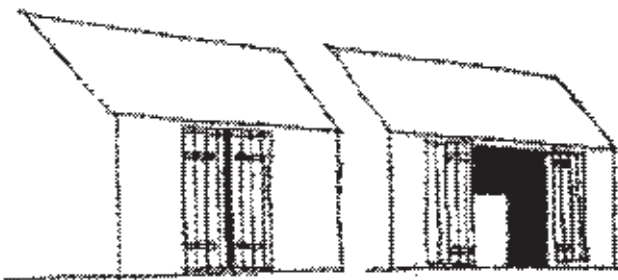
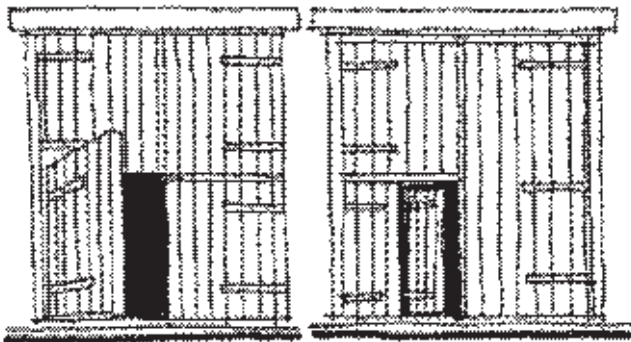
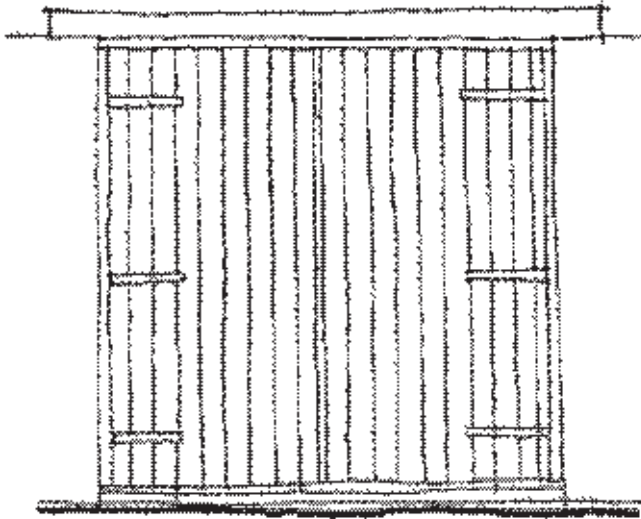

Where good doors remain, they can be retained as shutters allowing the opening to be used as a light source, or sealed in situ if daylight is not a problem.

Do, where appropriate, re-instate openings that have been bricked or blocked up in the recent past.

Do consider the detailing of any new screen inserted into the barn door opening carefully - the original door frame should be retained if possible. New framing should be formed using sawn indigenous hardwood (oak or elm) wherever possible, using simple, robust detailing. Areas that do not need to be glazed may be vertical boarded. A strong vertical emphasis should be retained.

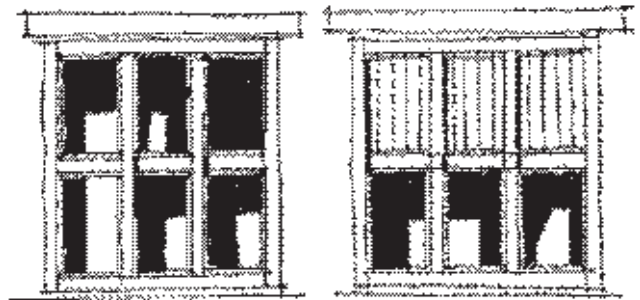

Do ensure that where a new 'Screen' is being inserted, the frame is recessed well back from the front face of the wall.

Do ensure that new screens are stained to reduce their visual impact. Generally black or ebony are considered the most appropriate colours. Where natural oak is used, a clear preservative should be used.

## WAGON DOORS - DON'TS

Don't under any circumstances, brick up existing wagon openings.

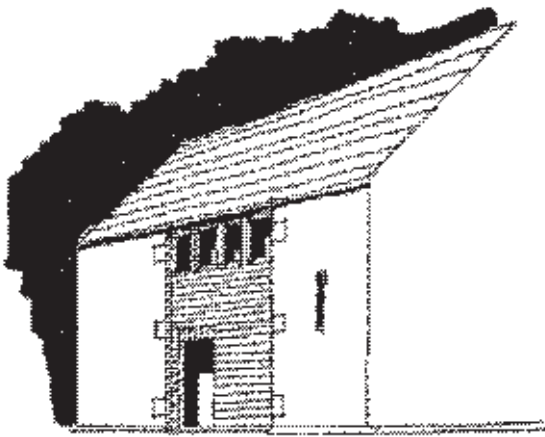
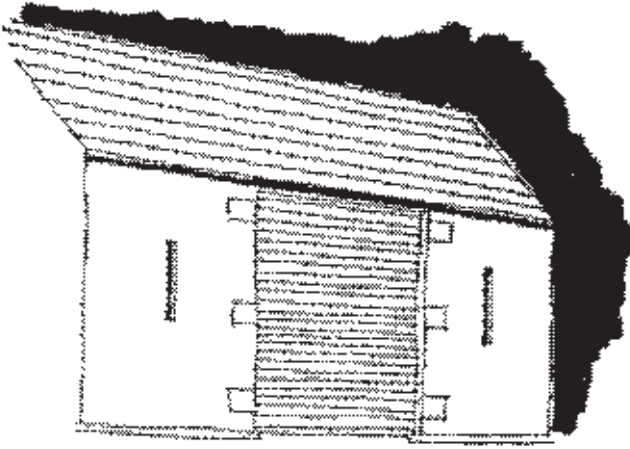

Don't introduce thin 'domestic' timber sections, inappropriate diagonal boarding, top hung windows or other false period detailing to any new entrance screen.

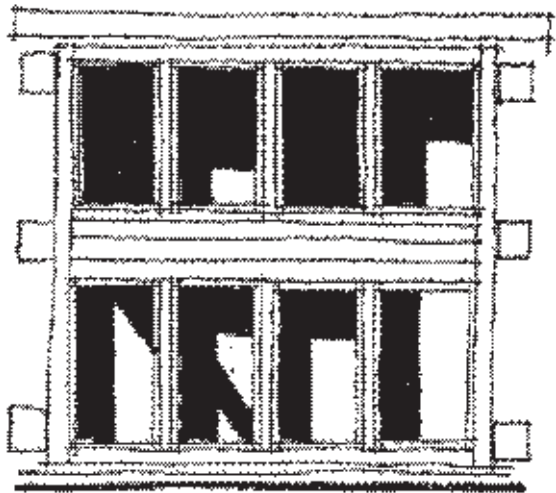
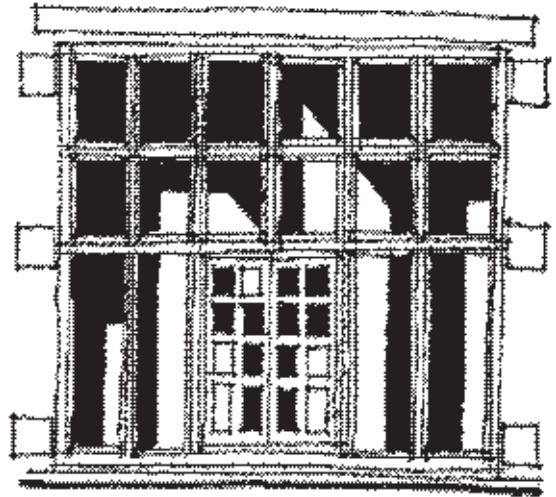
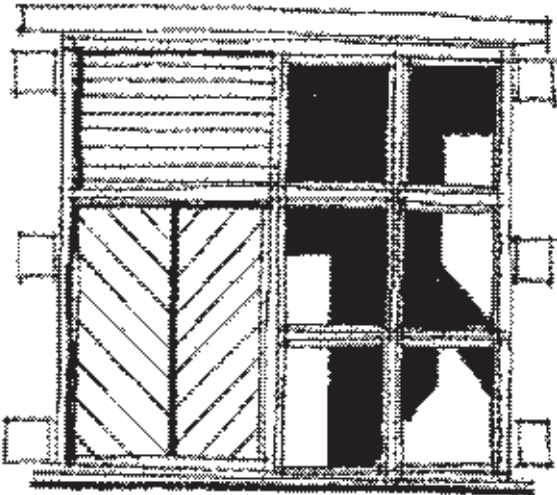

Don't introduce uPVC or aluminum elements.

Don't introduce domestic style iron mongery of fittings.

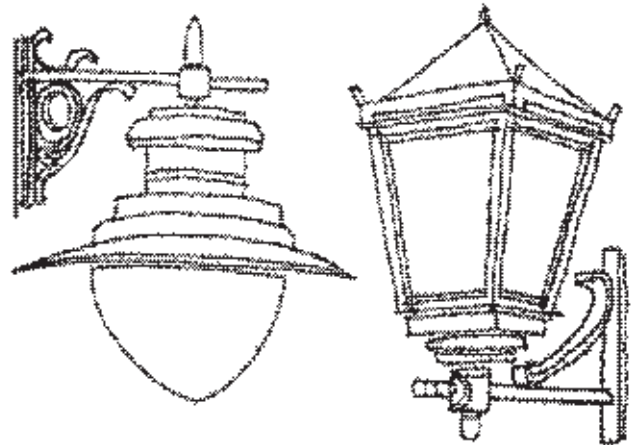

Don't fit reproduction period coach lamps or other inappropriate lighting elements. External lighting where necessary should be minimal and unobtrusive.

## DOORS - DO'S

Other than the main cart entrance there were few other openings to be found in most barns. In some instances, a door was added at later date to facilitate access. Like the main wagon doors, smaller doors would be characterised by their simplicity; vertical timber boarding with, some instances, top and bottom independently opening leaves.

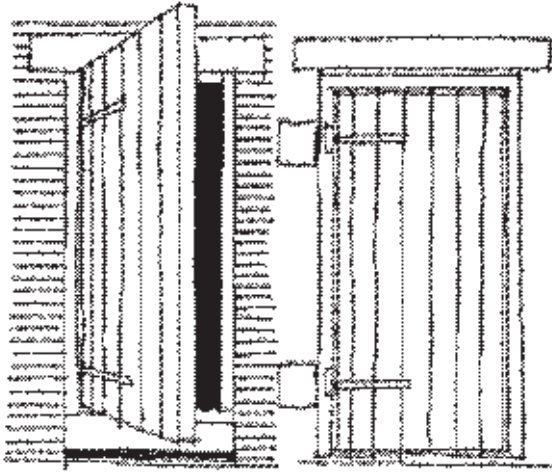

Do ensure that where appropriate, door framing and detailing matches that to be found on any existing openings. Generally for new doors robust timber grained sections of a simple vertical boarded design are the most satisfactory.

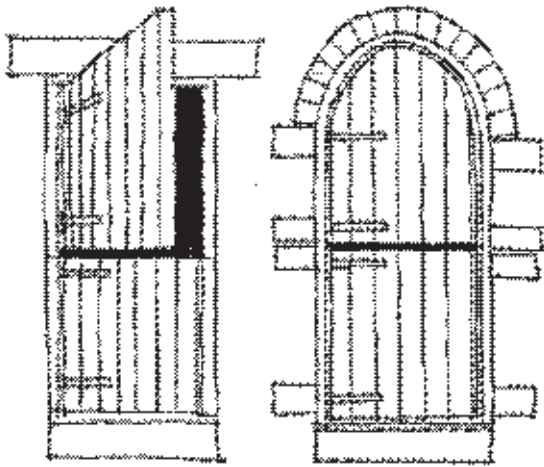
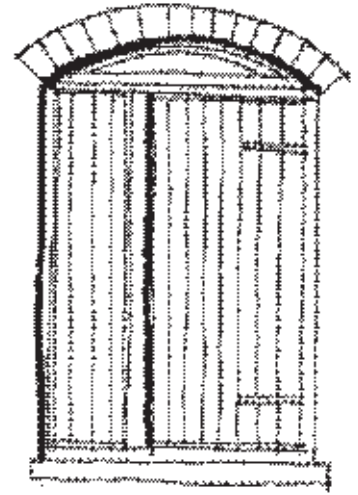
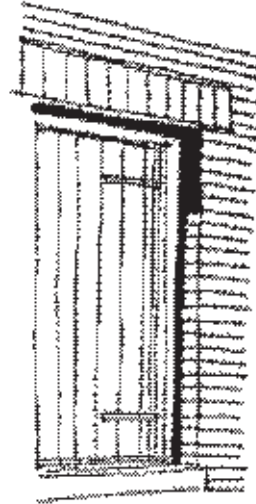

Do restrict the amount of new door openings to the absolute minimum.

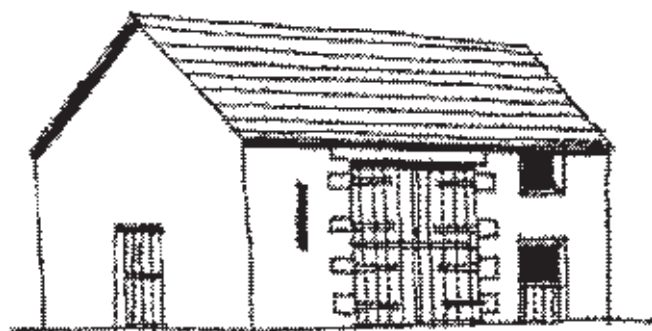
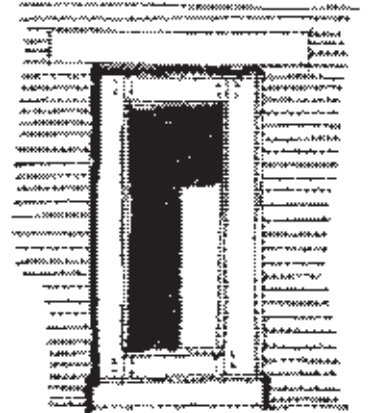
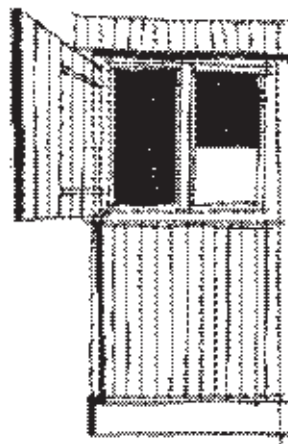

Do re-use existing door openings wherever possible.

Do consider re-instating any blocked up door openings where appropriate.

Do ensure that the door frames are recessed as far back as possible into brick or stone reveals rather than fixed flush with external face.

Do consider the choice of door furniture carefully. Designs should be simple, dark coloured and appropriate to a rural agricultural use rather than pseudo domestic examples or inappropriate reproductions.

Do ensure that the doors are painted or stained to reduce their visual impact. Generally, black or ebony are considered the most appropriate colours. Where natural oak is used, a clear preservative should be specified.

## DOORS - DON'TS

**Don't** use inappropriate domestic or period style doors or detailing. The use of aluminium or uPVC forms is not acceptable.

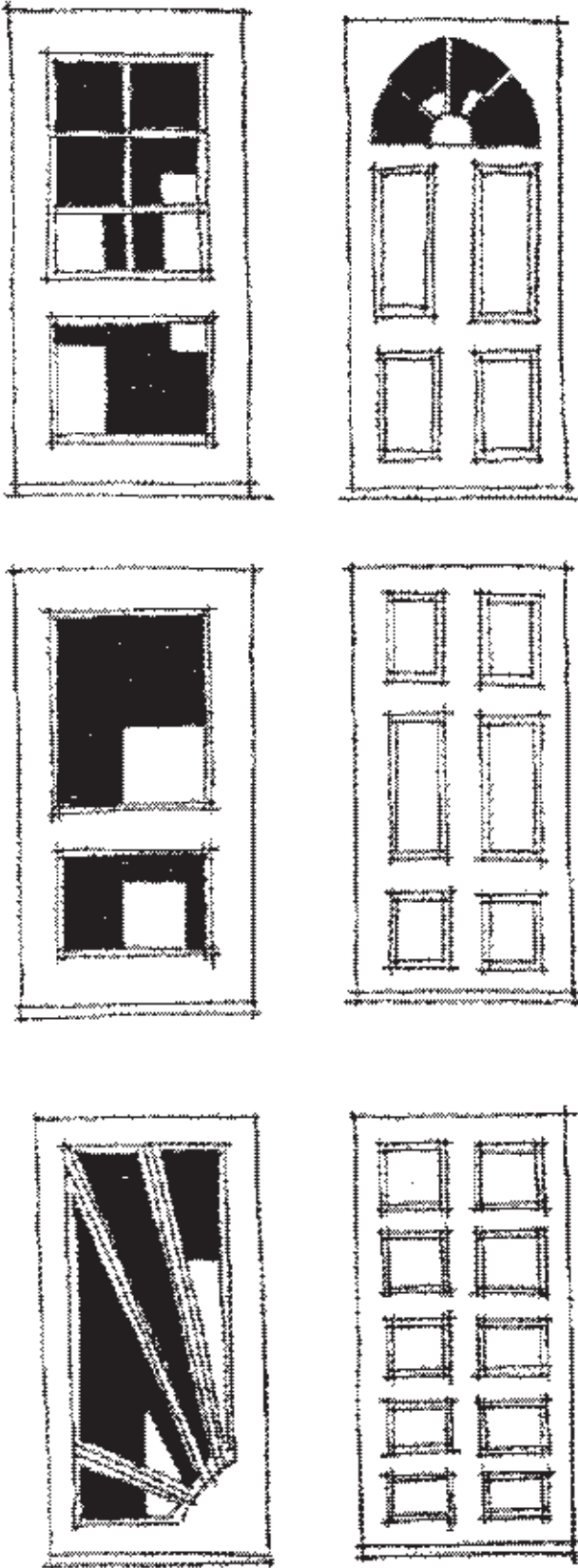

**Don't** use stock doors from a joinery catalogue - these are generally to "domestic" in style.

**Don't** introduce patio doors or 'French' Windows

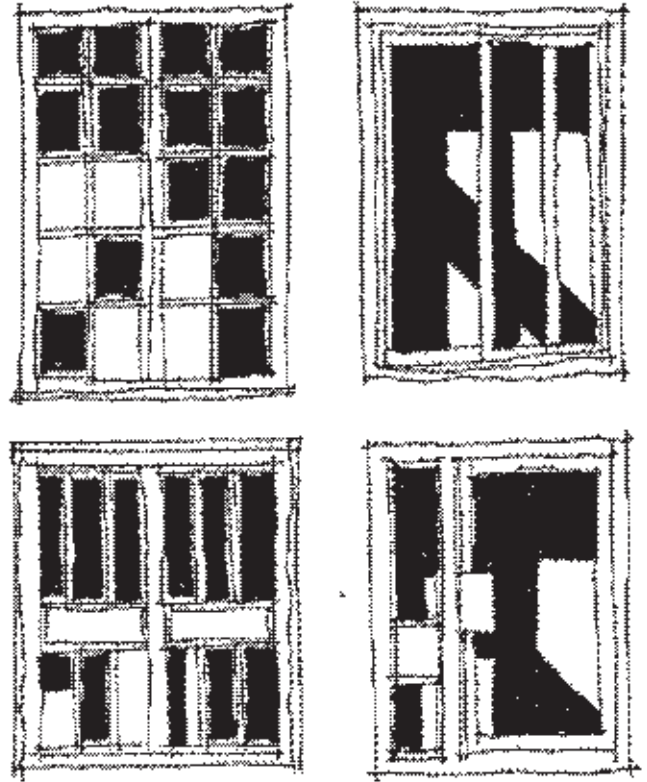

**Don't** use any form of frosted or obscure glass in a door.

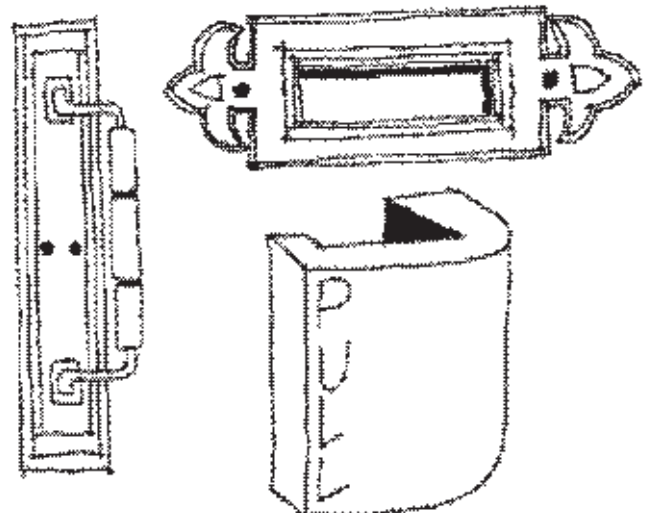

**Don't** use standard domestic, re-production brass or other similar inappropriate door furniture.

**Don't** paint or stain doors in bright, vivid colours.

## WINDOWS - DO'S

With the exception of the main cart doors and ventilation slots, barns are characterised by their lack of openings. Windows in particular are an alien feature; as a consequence their introduction has to be handled with extreme care to avoid adversely affecting the character of the building.

New windows should be located to provide the necessary daylight; not to provide views out.

Do restrict new window openings to the absolute minimum.

Do re-use existing openings wherever possible. Such features as loft openings, pitch holes, ventilation slots etc., can be used as valuable sources of additional daylight.

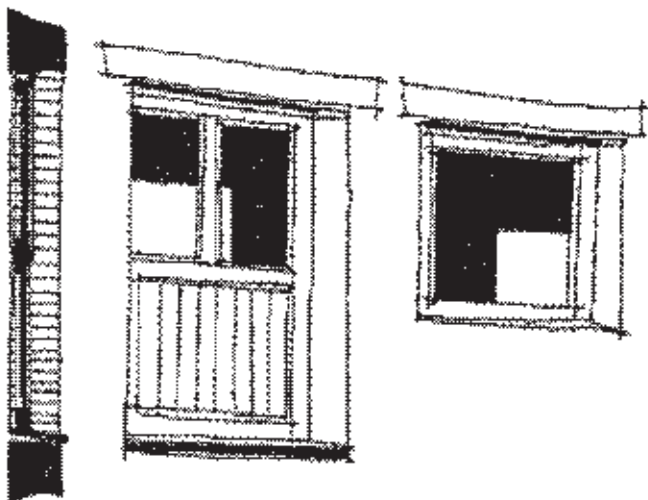

Do ensure that where appropriate, the window framing and surround detailing matches that to be found on any existing openings - generally robust timber framed sections of simple casement design are the most satisfactory.

Frames should be recessed as far back as possible into the window reveal.

Do consider re-using any existing cast-iron windows - they can often be repaired, renovated and re-used.

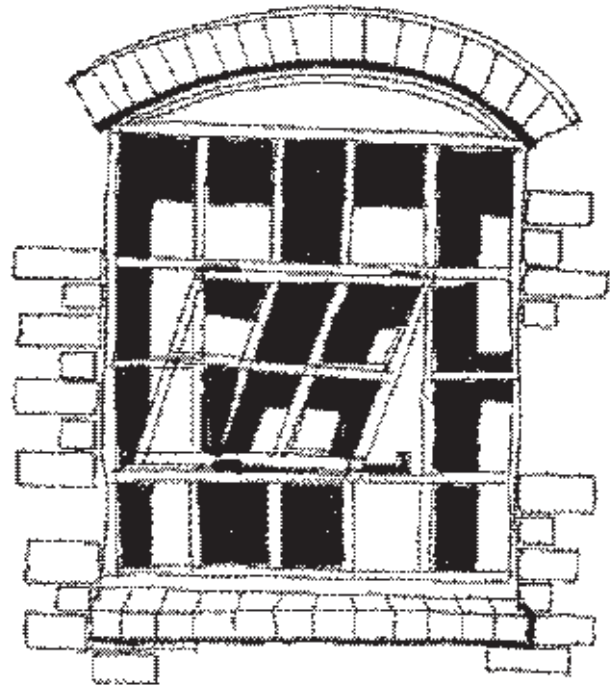

Do ensure that new windows in timber framed barns are located into the existing 'infill' panels so that cutting of timber members is avoided.

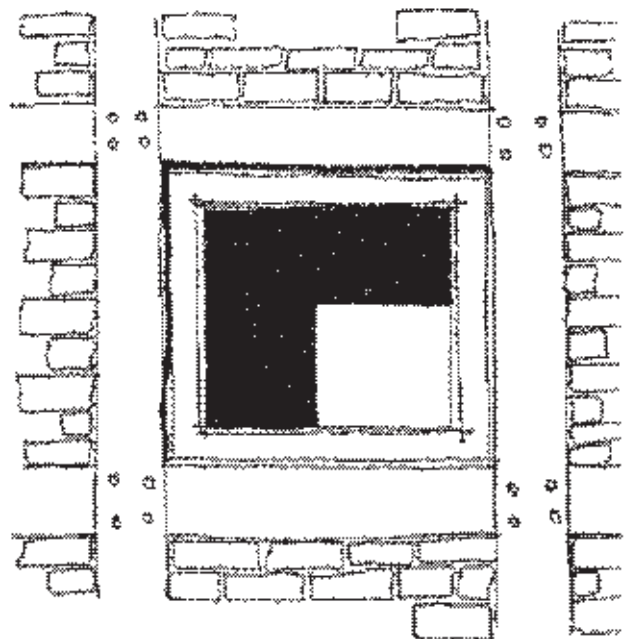

Do ensure that new window frames are painted or stained to reduce their visual impact.

Generally black or ebony are considered the most appropriate colours. Where natural oak is used a clear preservative should be used.

## WINDOWS - DON'TS

**Don't** replace unless absolutely necessary any original windows - cast iron windows in particular are worthy of greater attention. They were often inserted into farm buildings at a later date and thus form an integral part of the historic evolution of the buildings.

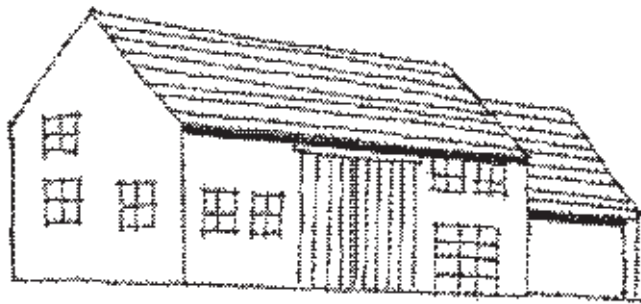

**Don't** introduce symmetrical rows of new windows - this is visually highly damaging.

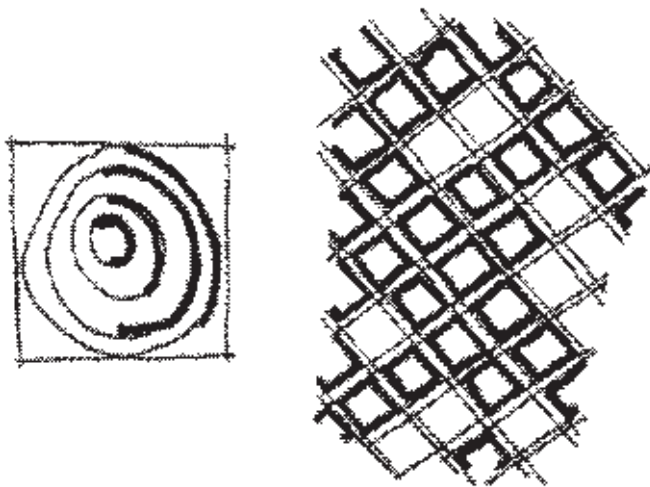

**Don't** use leaded, patterned or 'Bullseye' panes of glass.

**Don't** introduce contemporary or pseudo historic styles. Such forms, as bow, 'mock' Georgian or picture windows are inappropriate, as is the use of aluminum or uPVC materials.

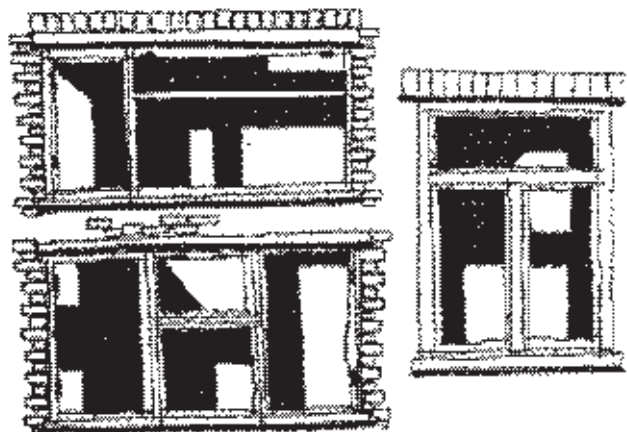
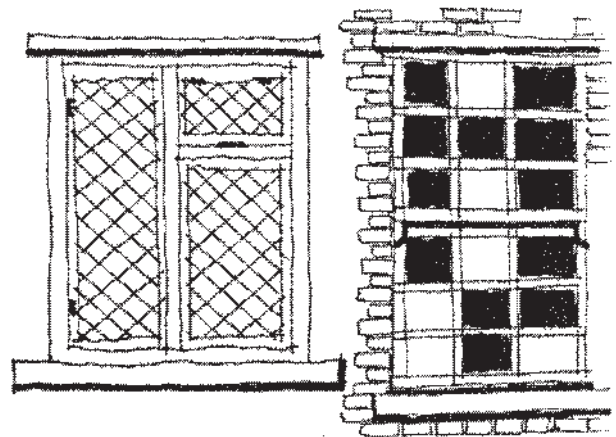
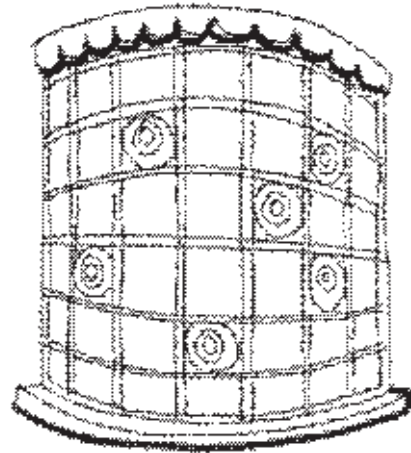

**Don't** paint or stain window frames in bright vivid colours.

## THE SETTINGS - DO'S

A barn's rural character, its raison d'etre is of paramount importance: nothing is so visually detrimental to this than the introduction of domestic elements.

In particular, open fields adjacent to and abutting barns should not be sub-divided to form urban gardens; it is essential to respect the setting of the building complex.

**Do** make use of existing walls and out buildings to screen new development.

**Do** provide garaging within the original building fabric.

**Do** keep additional screening walls to a minimum and ensure that they are constructed from traditional materials, e.g. brick or stone.

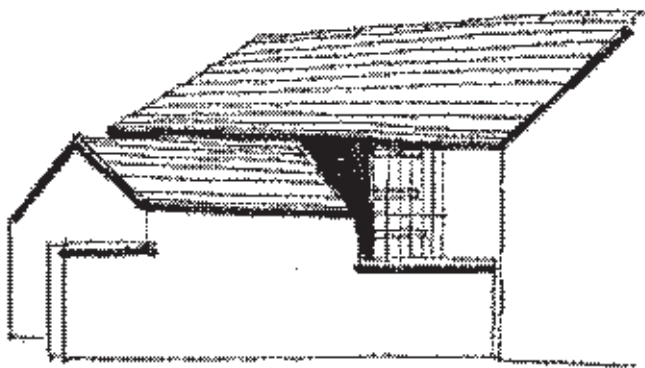

**Do** consider the siting of new domestic, or business service elements (such as liquid gas or oil tanks) carefully. Consideration could perhaps be given to housing such items in existing outbuildings to minimise visual impact.

**Do** consider carefully the surface treatment to any new hardstanding area, drives or pathways - such as surfaces should generally be of gravel or stone chipping finish with soft edging.

**Do** use appropriate indigenous species where hedge or tree planting is required.

**Don't** introduce domestic elements such as patios, planters, flower beds etc., outside existing screened areas.

**Don't** use inappropriate materials or construction techniques for new walls or screens, e.g. decorative concrete block walls, lapped timber fences etc.

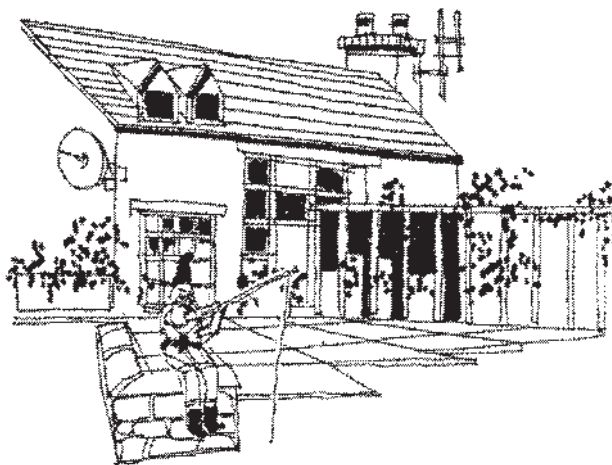

**Don't** construct separate new build garage facilities.

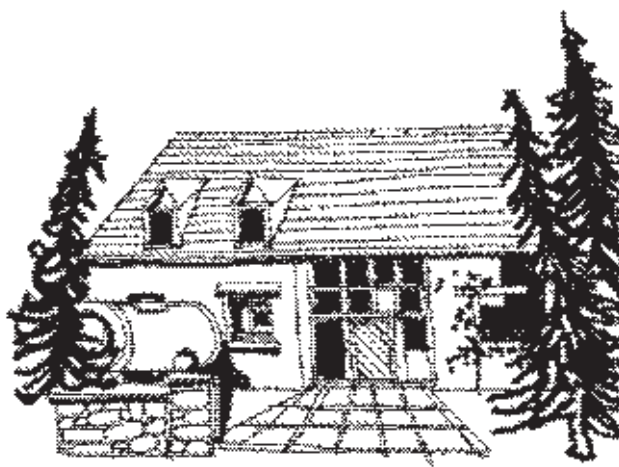

**Don't** site domestic, or business service elements in a visually obstructive position.

**Don't** use blocks, 'crazy' paving, tarmac or concrete for areas of hardstanding, driveways, parking areas, or patios.

**Don't** introduce hard concrete kerb edging.

**Don't** use inappropriate planting species such as quick growing conifers etc.

The Wildlife and Countryside Act 1981 makes provision for the protection of Owls, Bats and Bat roosts that may occupy agricultural buildings.

English Nature (formerly the Nature Conservancy Council) MUST, in any instance, be consulted where building work and/or timber preservation treatment is planned on a site frequented by bats - they will be able to advise on all the requisite legislative requirements.

Countryside Agency,  
1st Floor, Vincent House,  
Trindal Bridge,  
92-93. Edward Street,  
Birmingham. B1 2RA  
Tel: 0121 233 9399

English Nature,  
10-11. Butchers Row,  
Banbury,  
Oxfordshire.  
OX16 8JH  
Tel: 012295 257601

Rural Development Commission,  
National Rural Enterprise Centre,  
Stoneleigh Park,  
Warwickshire.  
CV8 2LZ  
Tel: 01203 696982

Ministry of Agriculture, Fisheries and Foods  
Regional Planning Advisor,  
Land Use Planning Unit,  
Berkeley Towers,  
Crewe. CV2 6PT  
Tel: 01270 69312

English Heritage,  
112 Colmore Row,  
Birmingham,  
Tel: 0171 973 3000

Society for the Protection of Ancient Buildings,  
35. Spital Square,  
London.  
E1 6DY  
Tel: 0171 377 1644

Warwickshire Wildlife Trust,  
Brandon Marsh Nature Centre,  
Brandon Lane,  
Coventry,  
West Midlands.  
CV3 3GW  
Tel: 01203 302912

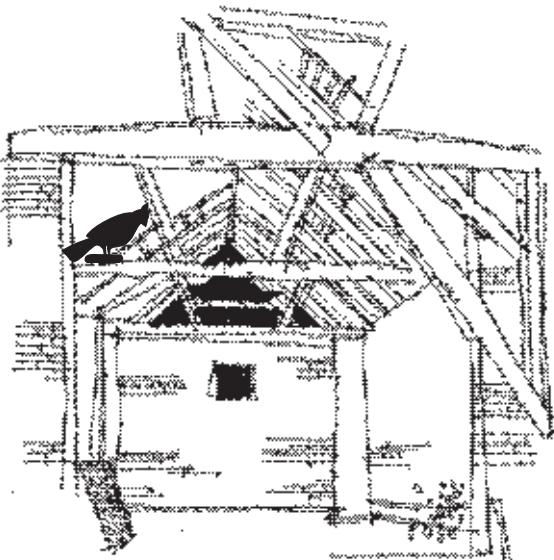

FOR FURTHER INFORMATION,

Brunskill, R.W.  
Traditional Farm Buildings of Britain. 1987

Essex County Council,  
Historic barns - A Planning Appraisal, 1979

English Heritage,  
The Conversion of Historic Farm Buildings

Hughes, G.  
Barns of Rural Britain, 1985

SAVE Britains Heritage,  
Darley, G.  
A Future for Farm Buildings, 1988

Society for the Protection of Ancient Buildings  
Barns Book. 1982

Warwick District Council - Planning and  
Engineering Department, Conservation Section,  
PO Box 2178  
Riverside House  
Milverton Hill  
Royal Leamington Spa. CV32 5QH  
Tel: (01926) 456509

