

Windows In Listed Buildings

& Conservation Areas



INTRODUCTION

This leaflet is intended as a guide to those considering the repair or replacement of windows in Listed Buildings and buildings in Conservation Areas.

Windows are a particularly important feature of all buildings and where ever possible, original windows should be retained as an important element of the design of the building. The two main types of windows discussed in this leaflet are sash and casement.

Other types or varieties of windows do exist and further specialist advice may be needed in these instances.

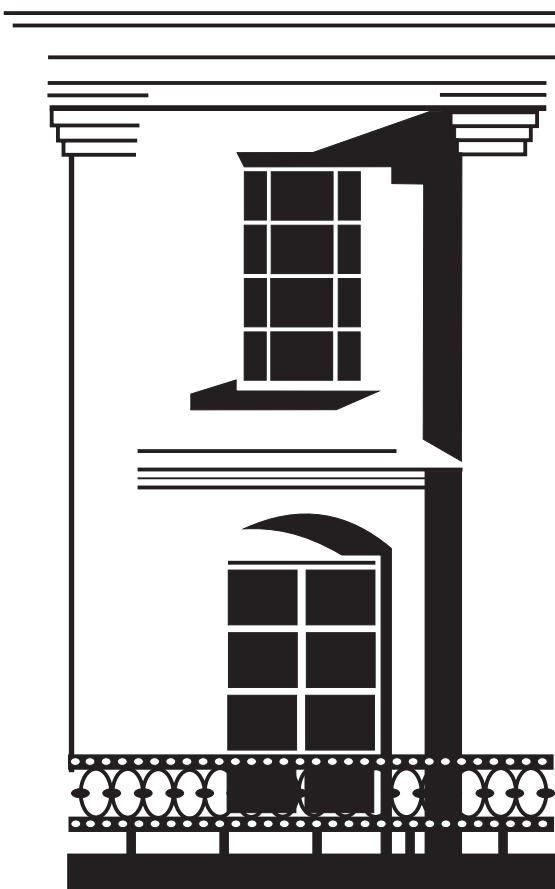

IN BRIEF

-- Listed Building consent is required to alter the design, material and colour of any windows in a Listed Building.

-- Listed Building consent is not required to repair any windows in a Listed Building where the original design, materials and colour are to be maintained.

-- Planning Permission is normally required to alter windows in all unlisted buildings which are not single dwelling houses. Where a modern building is within the Conservation Area, careful consideration is also needed in respect of replacement windows and early discussions with The Planning Department are recommended.

-- Planning Permission is required to alter windows in unlisted single dwelling houses where an Article 4 Direction is in force.

-- Listed Building Consent and Planning Permission will not be granted for the use of aluminum, plastic (U.P.V.C.), or non-traditional timber replacement windows in Listed Buildings or in unlisted buildings in Conservation Areas.

Please read this leaflet for detailed information.

If in doubt, please consult Warwick District Council Planning Department for further advice, clearly stating the address and present use of the property in question.

Head of Planning.

WINDOWS

October 2002
Conservation & Design
Warwick District Council



INVESTOR IN PEOPLE



"Warwick District Council strives to ensure that all people, regardless of ethnic origin or disability have equal access to its services. All information will be made available in braille, cassette tape or other languages, on request"



SASH WINDOWS

A Brief History

Sash windows consist of a pair of glazed panels which slide, usually vertically, in a case or frame. Weights housed in a case balance one or both sashes to which they are attached by cords passing over pulleys fixed in the case.

Sash windows first appeared in Britain in 1670 and generally had six panes of glass to each sash. Seventeenth and early eighteenth century sash windows generally had fairly thick ovolo moulded glazing bars and some examples of these remain in Warwick.

During the late eighteenth and early nineteenth centuries, glazing bars became thinner and the ovolo moulding gave way to the finer lambs tongue moulding. Pane sizes became more rectangular as the windows became taller - many examples of these elegant windows are to be found in Leamington spa. During the latter part of the nineteenth century, as larger pane sizes became possible the pattern of sash windows changed, frames often became heavier, with horns, and each sash was subdivided by a single glazing bar.

In some instances, single pane sashes were introduced and the character of some earlier properties changed by the removal of original glazing bars in preference for the single pane of glass. Throughout the nineteenth century variations were introduced such as margin lights and where wider windows were required, tripartite or triple sashes were introduced.

REPAIR OF SASH WINDOWS

Careful repair is always preferable to replacement. Decay in sash windows by moisture penetration can be prevented by through painting and regular maintenance. Where wet rot has penetrated a frame it is possible to splice in new pine sections to match the originals in all respects. Hardwood for replacement should generally be reserved for the cill.

It is essential that all sources of damp penetration are stemmed and in instances where open joints have given rise to problems, these may be closed by clamping, gluing, re-wedging and pinning. In some instances it may be necessary to take apart defective joints, in all cases timbers should be treated with a solvent borne preservative before refixing. Joints between window frame and wall were traditionally filled with haired mortar. Modern mastics may only be used where they can be applied in a discrete manner. It may be possible, where frames are removed for repair, to insert a damp proof membrane to isolate the frame from the masonry.

All sashes should be glazed using steel sprigs and traditional linseed oil putty. Glazing beads and modern glazing compounds are unsuitable. Some windows may retain original crown glass or cylinder glass - this is detected by its irregular surface and air bubbles. As crown glass is now very rare, original pieces should be retained and reused wherever possible - careful removal of such glass may be carried out by softening old putty. Although cylinder glass may be obtained from specialists, a cheap alternative is 2mm 'horticultural' glass.

Bulls-eye glass is not traditional and should never be used in sash windows. Similarly, double glazed units should never be inserted into original frames. (See 'Replacement windows' for double glazing).

Broken sash cords should always be replaced - these may either be of cotton, jute or nylon and can be kept flexible by waxing. New metal weights can be obtained if the originals have gone missing. The introduction of any form of spring balance mechanism is unacceptable in an original sash window.

It is essential with any type of repair to ensure that the weight of the sash frame remains unaltered otherwise the counter-balance mechanism will not function properly. This is why it is important that the original or 2mm glass is used for reglazing to avoid increasing the weight of the frames. Original sash windows need not be draughty if properly repaired. Proprietary draught strips which are concealed behind staff and parting beads, may be fitted to assist.

REPLACEMENT OF SASH WINDOWS

Replacement of a sash window should only be carried out where the window is beyond repair or where a historically incorrect window is to be replaced by correct detailing.

All forms of U.P.V.C. and aluminium windows are unacceptable as replacements in Listed Buildings and in most unlisted buildings in Conservation Areas.

Imitation sash windows, which often consist of top-hung hinged sections, are also unacceptable. Where a defective window is to be replaced it should match, in all respects, the original window detailing. This must include materials, size of panes, size of frame, width of glazing bar, mechanism, ironmongery, and any detailing associated with the internal or external surround of the window.

It is not acceptable to omit mitred detailing at the intersection of glazing bars or to introduce projecting frame sections for opening lights where these did not exist originally.

These principals should be followed for all Listed Buildings and replacement of original windows to unlisted buildings within the Conservation Areas.

It is important to note that most sash windows before 1870 did not have horns and these should not be included in replacement windows where they did not previously exist. Spring balances are not an acceptable form of mechanism for historical replacement windows - these may only be considered for new works.

Sash windows are normally painted white unless a historical precedent exists for other colours. Stained timber windows are unacceptable.

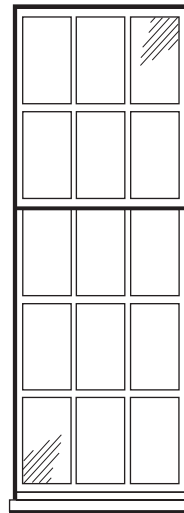
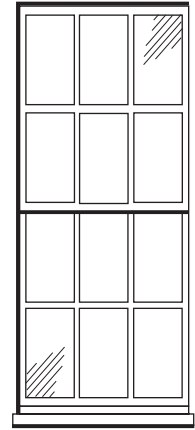
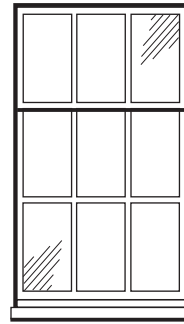

Examples of early nineteenth century sash windows

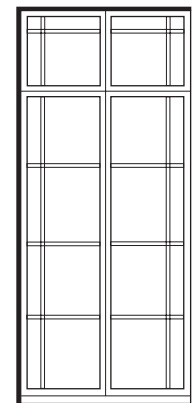

An example of an early to mid nineteenth century sash window and a french casement window with margin lights.

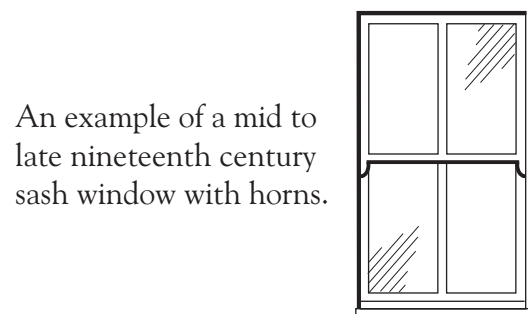

An example of a mid to late nineteenth century sash window with horns.

CASEMENT AND FIXED LIGHT WINDOWS

A Brief History

Casement windows are generally those with a side hung hinged opening light as opposed to a window which is fixed and does not open. A window may consist of both fixed and casement opening lights.

Casement windows have much earlier origins than sash windows and were developed as glass became more widely available following the mediaeval period.

The most frequently encountered early form of casement are those with leaded lights, where each piece of glass is held into position by a lead strip. This type of window existed in various forms from the mediaeval period onwards and may be found in both stone mullion windows and timber frames.

As glass sizes became larger, timber glazing bars were introduced often with quite fine lambs tongue sections similar to those used for sash windows. In some instances, iron glazing bars were used in the nineteenth century, set in timber frames, often in conjunction with larger pane sizes.

The types of casement and fixed light windows are numerous and many different historical examples still survive. The design of casement windows has developed during this century with the use of various foreign hardwoods, metals, aluminium and U.P.V.C. These materials are generally alien to historic buildings as are the patterns of windows made from these materials.

REPAIR OF CASEMENT WINDOWS

Careful repair is always preferable to new work. Decay in timber windows by moisture penetration can be prevented by through painting and regular maintenance. Where wet rot has penetrated a frame it is possible to splice in new sections to match the originals in all aspects including using compatible timbers. It is essential that all sources of damp penetration are stemmed and in instances where open joints have given rise to problems, these may be closed by clamping, gluing, re-wedging and pinning. In some instances it may be necessary to take apart defective joints, in all instances timbers should be treated with a solvent-borne preservative before refixing.

Joints between window frame and wall were traditionally filled with haired mortar. Modern mastics may only be used where they can be applied in a discrete manner. It may be possible, where frames are removed for repair, to insert a damp-proof membrane to isolate the frame from the masonry.

All timber windows should be glazed using steel sprigs and traditional linseed oil putty.

Glazing beads and modern glazing compounds are unsuitable.

Some windows may retain original crown glass or cylinder glass or even fragments of mediaeval glass - this is detected by its irregular surface, air bubbles, or green colour. Original pieces should be retained and reused where ever possible - careful removal of such glass may be carried out by softening old putty on leaded lights. Although cylinder glass may be obtained from specialists, a cheap alternative is 2mm "horticultural" glass.

Modern bulls - eye glass is not traditional and should never be used when reglazing. Similarly, double glazed units should never be inserted into original frames.

Where original leaded lights remain, they should always be conserved. Generally, specialist advice should be sought for these type of repairs Iron frames and iron glazing bars should also be conserved and, if necessary, iron glazing bars should be reset in new timber frames.

Many different examples of catches, fasteners and hinges exist and these should always be repaired if necessary, and reused.

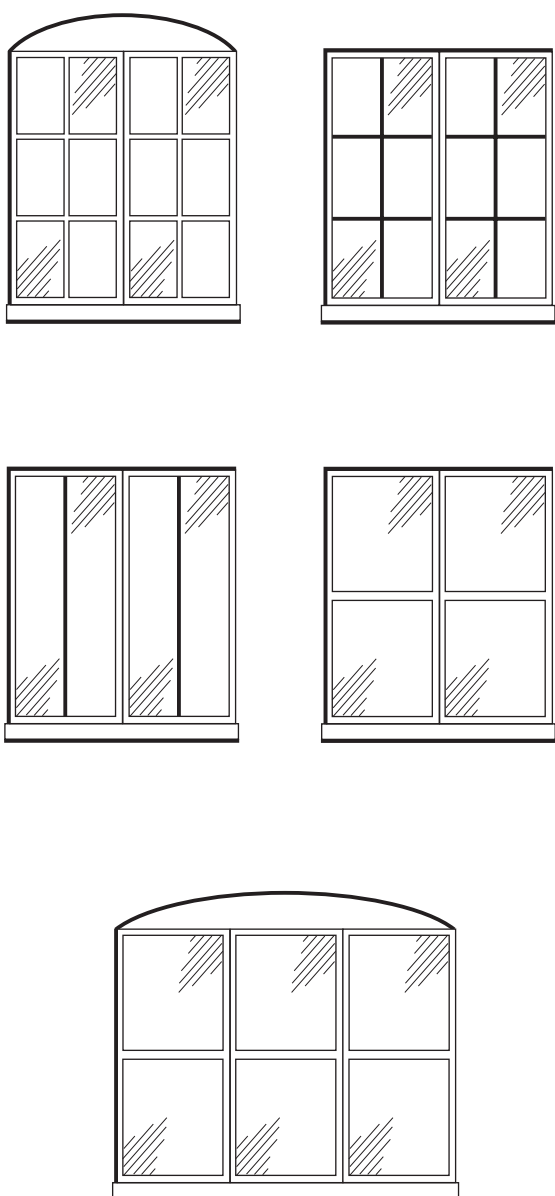

Examples of eighteenth and nineteenth century casement windows

REPLACEMENT OF CASEMENT WINDOWS

Replacement of casement and fixed light windows should only be carried out where the window is beyond repair or where an historically incorrect window is to be replaced by correct detailing. In the latter instance, specialist advice should be sought to ensure correct historical replacement are achieved.

All forms of U.P.V.C. and aluminium windows are unacceptable as replacements in Listed Buildings and in most unlisted buildings in Conservation Areas.

New leaded lights should always be made to the traditional specification. The overlaying of lead on single sheets of glazing is unacceptable.

When a defective window is to be replaced it should match, in all respects, the original window detailing. This must include materials, size of panes, size of frame width of glazing bar, mechanism, ironmongery, and any detailing associated with the internal or external surround of the window. It is not acceptable to omit mitered detailing at the intersection of glazing bars or to introduce projecting frame sections for opening lights where these did not exist originally.

These principals should be followed for all Listed Buildings and replacement of original windows to unlisted buildings within the Conservation Areas.

Casement windows are normally painted unless a historical precedent exists for other finishes, stained timber windows are not normally acceptable.

Typical glazing bar moulding

Types 1 to 5 are acceptable for use in historic buildings.

Types 6 and 7 are unacceptable modern versions.

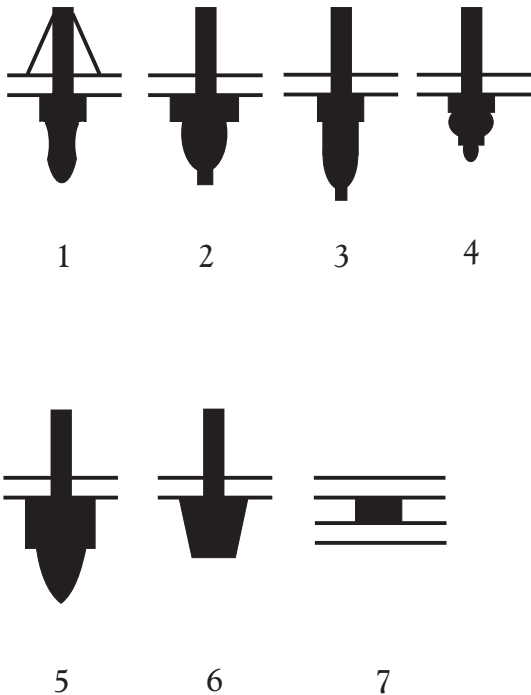

- 1 - Lambs Tongue
- 2 - Ovolo
- 3 - Gothic
- 4 - Broken Lambs Tongue
- 5 - Early C19 Glazing Bar
- 6 - Modern Timber
- 7 - Modern U.P.V.C. Glazing Strip

DOUBLE GLAZING

The use of double glazed units is not acceptable in replacement sash or casement windows with glazing bars. It is not possible to obtain the very fine glazing bars, required in many instances to support double glazed units and the view of the window is distorted by the sandwich effect of the two sheets of glass. The integrity of the window is also lost as a historical component and the weight is changed considerably in respect of the original counter - balances in sash windows. Secondary glazing can be equally efficient as double glazed units and, if fitted discretely, need not effect the character of the building. In this respect, it is important that secondary glazing units correspond closely with the original window pattern.

The use of all forms of glazing bars either sandwiched between double glazed units, or stuck onto the surface of single sheet double glazed units are unacceptable. This includes stuck - on leaded lights and stuck - on timber glazing bars used in conjunction with sandwiched glazing bars.

Individual secondary glazing is more effective for sound proofing.

Proper restoration and draught proofing of windows can greatly increase their thermal effectiveness which may warrant double glazing unnecessary.

With some single pane casements and fixed lights, it may be acceptable to consider a double glazed unit where the need to support the unit does not conflict with the required frame size or where the sandwich effect of the glass will not detrimentally affect the appearance of the building. This kind of approach is not acceptable to the repair of original sash windows or to most historical replacements, or where it is important to maintain the historical window design as part of the integrity of the building.

WINDOWS IN NON-TRADITIONAL AND NEW BUILDINGS IN CONSERVATION AREAS

Windows in new traditional style buildings within Conservation areas should, in general, follow the principals set out for either sash or casement windows in the foregoing sections. New buildings are required to meet the current Building Regulation standards and therefore double glazing is required. Where it is proposed to use small-paned windows, or traditional leaded lights, secondary glazing must be used. It is inappropriate to use double glazed units within small paned windows as this will increase the glazing bar size and necessitate the need for glazing beads to be used rather than putty but increasing the overall size of the frame to unacceptable proportions which do not relate to traditional window designs. Many windows produced by standard joinery manufacturers result in this unfortunate effect where small paned windows are to be used. To avoid this effect, it may be appropriate to look to larger paned windows with fewer glazing bars, where the proportion will not be distorted in the way described. These are aspects of design which must be considered at the outset when considering any form of new build within the Conservation Area. Use of stuck on or applied leaded lights in modern windows, within Conservation Areas is also considered unacceptable.

Where a contemporary building is proposed, it may be acceptable to consider materials other than timber, however, such an approach must be developed as part of the overall design of the building and should be discussed at an early stage with Warwick District Council Planning department. It should be noted that many good contemporary buildings within Conservation Areas are designed using traditional materials.

ROOF WINDOWS/ROOFLIGHTS AND THE INTRODUCTION OF ROOF LIGHTS IN TRADITIONAL ROOFS.

Roof windows that follow the line of the roof became popular in the 19th century as a means of lighting stairwells and small attic rooms. These were usually discreetly located on the rear roof slope. In recent years, with the mass production of preparatory roof lights, these have been in popular demand for helping to access useful space within the roof. They can however have a detrimental effect on the quality and appearance of the building. Large sheets of glass in a traditional roof can seriously detract from the overall appearance of the building. As in the past, discreet placing of roof windows is the only acceptable solution, either behind parapets or on a less visible rear slope. Rooflights to a traditional design are now available and should always be used in listed buildings and buildings within Conservation Areas to avoid the considerable upstand that, which most modern roof windows have.

The introduction of discreet roof windows may overcome the need for dormer windows, where these would be considered an unacceptable addition to the building.



The effects of unsympathetic replacement windows and doors.

DORMER WINDOWS AND THE INTRODUCTION OF DORMER WINDOWS IN TRADITIONAL ROOFS

Where a building already has dormer windows, they should be repaired and/or replaced in line with the principles set out in this leaflet either casement windows, sash or whichever the dormer contains. Where new dormer windows are proposed to be inserted into an existing roof which already had dormer windows, it should not be assumed that further dormers can always be added to the traditional roof and advice should always be sought in each instance.

Where it is agreed that additional dormers can be successfully integrated into the existing roof, it is usually appropriate to match the style and detailing of the existing dormers.

Where it is intended to introduce new dormer windows into a roof which has never had dormer windows previously, great care is needed to ensure that they can be properly integrated into the design of the property as a whole. Wherever possible the principles of traditional dormer windows should be used and in all cases where planning permission or listed building consent has been granted, large scale working details will be required by the District Council to ensure the window has been appropriately detailed.

The District Council's Design Guidance Leaflet for Roofs On Listed Buildings and within Conservation areas contains information relating to dormer windows.

Where additional accommodation is being sought by the introduction of dormer windows, the impact on the external appearance of the building must first be assessed in order to determine the scope for achieving the required additional accommodation.

It is not appropriate to accommodate large-box dormer windows into properties in order to provide additional living accommodation at attic level, since such features are invariably out of scale with the original roof of the property.

In certain instances it may be possible to carefully assess the accommodation within the existing roof and to look at alternative staircase locations to avoid the need for large box dormers which would not receive planning permission.

Buildings within Conservation Areas require planning permission for the introduction of dormer windows and further additions or alterations to the roof and in the case of Listed Buildings, listed building consent is always required for such works.



A typical Regency property with original windows and french casements.

IS PERMISSION NEEDED TO REPAIR OR REPLACE WINDOWS?

Listed Building consent will be required for all replacement windows in Listed Buildings that are not exact copies of the original window in traditional materials as outlined in the section entitled "Replacement Windows" in this leaflet.

Listed Building consent would not normally be granted for replacement windows of a different design, unless they are to replace non-traditional modern windows with a more appropriate historical design.

Listed Building Consent is not required for repairs to windows in Listed buildings if carried out as outlined in the repairs section in this leaflet. Any repairs which do not follow these guidelines will require Consent.

Planning Permission will be required for the replacement of windows in some unlisted buildings. Planning Permission will be required to alter the design of any windows in the building which is not a single dwelling house, as this may constitute a material alteration to the building. Permission may also be required to alter windows in a single dwelling house where permitted development rights have been removed by the service of a direction made under Article 4 of the General Development Order 1988. Such directions would be available from Warwick District Council Planning Department.

In any event, the principles set out in this leaflet should be adhered to for all buildings within Conservation Areas. In some instances, modern materials may be appropriate in the context of modern buildings within the Conservation Areas.

The advice of The Planning Officer should, however, be sought in these cases.

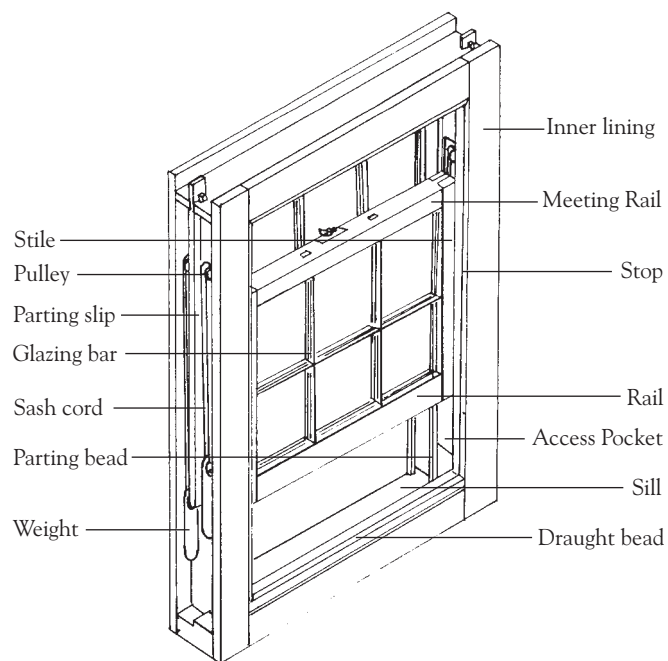

Anatomy of a Georgian sash

For Further Information, Contact :-

Warwick District Council Planning Department.
John Archer, Planning Officer
BA, MCD, MRTPI.

Conservation & Design Section
PO Box 2178
Riverside House
Milverton Hill
Royal Leamington Spa
CV32 5QH

Tel: (01926) 456508 Extension: 6508
Fax: (01926) 456542

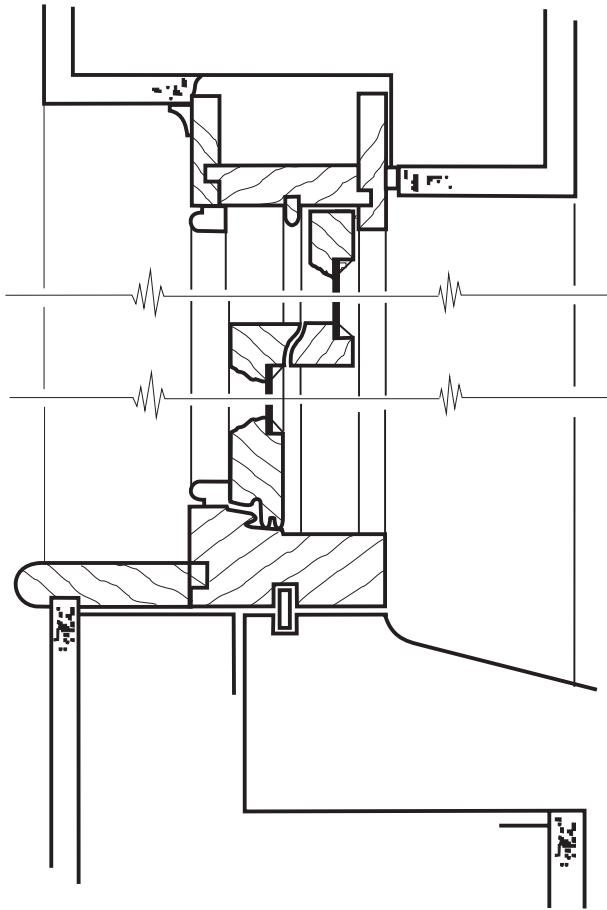

Meeting rails very narrow

Timber cill should not project beyond outer lining

Stone or rendered cill

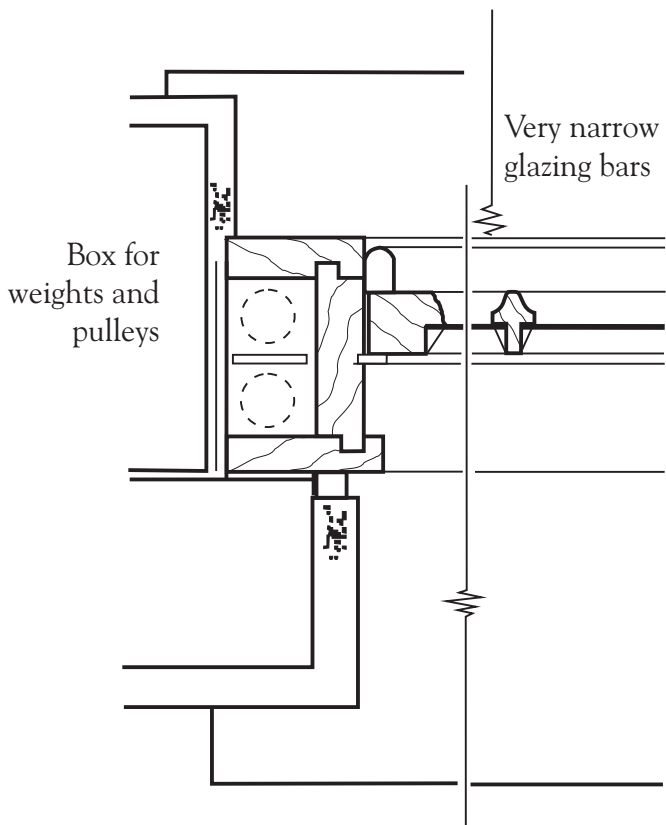

Very narrow glazing bars

Box for weights and pulleys

Section showing typical sash window construction. The detailing of each window needs to be compared with the original sash windows on site - this drawing should not be used as a standard detail.



Full size section through early C19 glazing bar